

P.C.B LAYOUT MOUNTING PATTERN

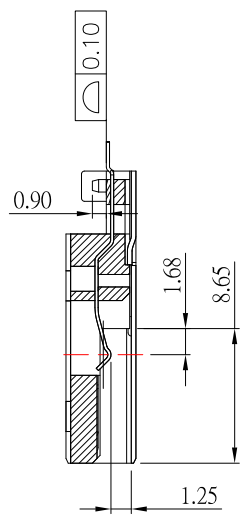
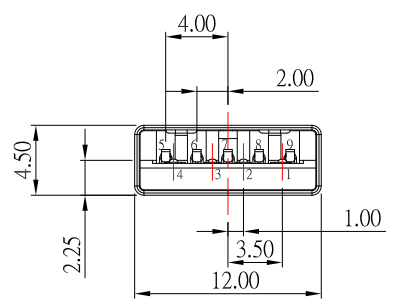

SECTION "A-A"

SUA-111M2-30xx-S277

鍍層厚度:      COLOR :

Blank : 1u"	BLUE : Blank
2 : 15u"	Black : B
3 : 30u"	Red : R

Pin NO.	SIGNAL NAME
1	VBUS
2	D-
3	D+
4	GND
5	StdA_SSRX-
6	StdA_SSRX+
7	GND_DRAIN
8	StdA_SSTX-
9	StdA_SSTX+
Shell	Shield

NOTE:

- MATERIAL:
  - INSULATOR: LCP, UL 94V-0
  - CONTACT: PHOSPHOR BRONZE
  - SHELL: SPCC
- PLATING:
  - CONTACT: Plated Gold in Mating Area ;  
Tin Plated on Solder Balls ;  
Nickel under plated overall
  - SHELL: Nickel under Plated surface layer
- ELECTRICAL CHARACTERISTICS:
  - CURRENT RATING: 1.5 Ampere Min
  - VOLTAGE: 30VAC(R.M.S)
  - CONTACT RESISTANCE: 30mΩ MAXIMUM
  - DIELECTRIC WITHSTANDING VOLTAGE: 500 VAC
  - INSULATION RESISTANCE 100 MΩ MIN
  - ENVIRONMENTAL: -55°C ~ 105°C

**CONTACT** 建倚科技股份有限公司  
CONTACT TECHNOLOGY CORP.

TOLERANCE UNLESS OTHERWISE STATED :  
 Up to 5 ±0.2  
 Above 5 ~ 15 ±0.3  
 Above 15 ~ 30 ±0.4  
 Above 30 ~ 50 ±0.5  
 Angle ±0.3°

3RD. ANGEL'S



UNITS MM

DRAWN BY: Jack Lu      DATE: 03/09/22  
 CHECKED BY: Jacky Chen      DATE: 03/09/22  
 APPROVED BY: Tony Kao      DATE: 03/09/22

MAT'L		TITLE	CONNECTOR
FINISH		MODLE	USB A/M SMT TYPE 沉板1.95mm
SCALE	1 : 1	DWG NO.	SUA-111M2-30xx-S277
SHEET NO.	1 of 1	PART NO.	SUA-111M2-30xx-S277
		SIZE	A4
		VER	R2

ITEM NO.	DESCRIPTION	DRAWN	DATE
2	新增PIN定義	Jack	030922
1	更新為A0版	Jack	080516